

MODEL: 8015

15' TRIPOD

- Weight Limit 300 lbs.
- Do Not Over Tighten Fasteners

Instruction and Safety Manual

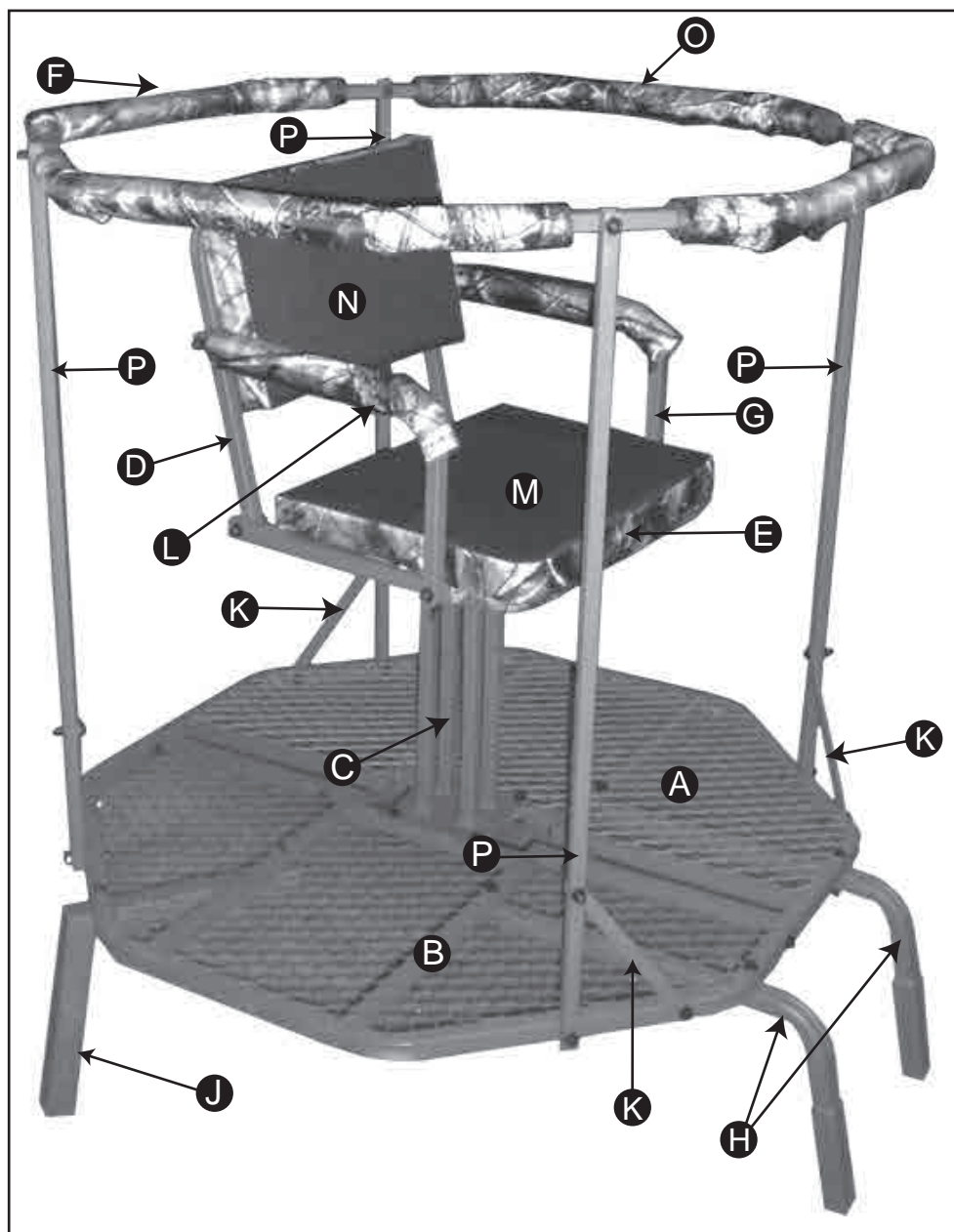

Warning

Every year serious injury and even death occurs from hunting related falls. To ensure your safety, please **COMPLETELY** read and follow this safety manual and **ALL** warning labels **BEFORE** assembling, installing or utilizing this product.

DO NOT USE THIS PRODUCT BEFORE FULLY UNDERSTANDING ALL SAFETY WARNINGS AND INSTRUCTIONS. IF YOU HAVE QUESTIONS, ARE UNSURE ABOUT ANY INFORMATION OR NEED ADDITIONAL INFORMATION CONCERNING YOUR PRODUCT, CONTACT OUR CUSTOMER SERVICE DEPARTMENT AT 1-866-972-6168 OR VISIT WWW.PRIMALVANTAGE.COM. KEEP AND MAINTAIN THIS SAFETY AND INSTRUCTION MANUAL IN A SAFE LOCATION FOR FUTURE REFERENCE.



TRIPOD SAFETY WARNINGS

Please read the following instruction manual and warnings labels completely before utilizing this product. Failure to understand and execute the instructions and warnings may result in serious injury or death. In the event of an accident, have a plan for rescue, including the use of devices that may be easily reached while suspended.

ALWAYS read and understand all warnings and instructions including assembly, installation etc., before each use of this product. Failure to read and understand all warnings and instructions may result in serious injury or death. Contact a Customer Service Representative with any questions you may have.

NEVER exceed total weight limit of **300 lbs.** **DO NOT** use if your combined weight with all of your hunting gear and any accessories exceeds **300 lbs.** Use of tripod over the weight limit may result in serious injury or death.

DO NOT use this tripod while under the influence of alcohol, medication or any illegal substances. Use of tripod while under the influence of any of these substances may result in serious injury or death.

NEVER use this tripod during inclement weather. **DO NOT** use Tripod during thunderstorms, snowstorms, hurricanes, tornadoes or any other weather conditions that include (but not limited to) lightning, icy conditions, or high winds that could create slippery or dangerous situations. End your hunt and return to the ground if inclement weather conditions arise.

NEVER use tripod if you are feeling ill, nauseous, dizzy or if you have a prior condition that could cause a problem. i.e., heart condition, joints that lock-up spinal fusions, etc., or if you are not well rested and alert. Physical ailments can reduce your ability to safely install, utilize, and remove your treestand. Please consult a physician prior to use.

NEVER use this tripod if you have a history of health problems such as (but not limited to) heart problems, back problems, high blood pressure, impaired vision, equilibrium impairments, are afraid of heights, have been advised by a doctor or physician not to climb. If you are not physically fit, well rested, and alert, or if you have any other physical or mental condition that would impair your ability to properly use this treestand.

NEVER jump or bounce on the tripod's platform or ladder sections. Instead, step firmly on the first rung of the bottom ladder section to set the ladder into the ground before proceeding to climb the ladder.

NEVER transport any of your equipment with yourself while ascending or descending the ladder. You will need to have two hands free during ascending and descending for safety. Use a haul line to pull up your firearm (unloaded, chamber opened with safety lock engaged, barrel facing towards the ground), bows, arrows, knives or any other equipment to your tripod once you have reached your desired hunting height. Prior to descending, lower your equipment on the opposite side of the tripod from which you are climbing. Make sure that the unloaded firearm's safety lock is engaged and the gun barrel is pointing towards the ground.

ALWAYS hunt with a plan and a buddy. Before you leave home, let others know your exact location, when you plan to return and who is with you.

ALWAYS carry emergency signal devices such as a cell phone, walkie-talkie, whistle, signal flare, PLD (personal location device) and flashlight with you at all times and within reach even while you are suspended in your harness. Watch for changing weather conditions. In the event of an accident, remain calm and seek help immediately.

ALWAYS inspect the tripod for signs of wear or damage **BEFORE** each use. Also inspect to ensure that nuts and bolts are secure. Destroy all products that cannot be repaired by the manufacturer. Contact a Customer Service Representative for replacement parts.

NEVER modify your tripod in any way by making repairs, replacing parts, or altering, adding or attaching anything to it except if explicitly authorized in writing by the manufacturer. Improper installation or adjustment may cause serious injury or death. Remove all contents from box. Inspect for any damaged or missing parts. If any parts are missing or damaged, you must only use certified replacement parts. Using any other replacement parts will void product warranty. **THERE ARE NO EXTRA PARTS.** All parts **MUST** be used to ensure the safety of you and your stand. If you think parts are missing or damaged, **STOP IMMEDIATELY** and contact our Customer Service Department. Using the tripod with missing or damaged parts may result in serious injury or death. **DO NOT** return this product to the retailer. Contact a Customer Service Representative if you have any missing, damaged or extra parts.

ALWAYS keep instructions in a safe place and review before each use. It is the responsibility of the tripod owner to furnish the complete instructions to anyone who borrows or purchases the treestand from you.



Distributed by Primal Vantage Company Inc. 685 Route 10 Randolph, NJ 07869

2013
©2013 (rev. 02/13)

CUSTOMER SERVICE DEPARTMENT 1-855-212-4047

WWW.PRIMALVANTAGE.COM

TRIPOD SAFETY WARNINGS

NEVER use this tripod for any use other than hunting.

NEVER use this tripod for trimming trees.

NEVER fall asleep in your stand as you may fall out resulting in serious injury or death.

ALWAYS be sure to retighten all bolts **BEFORE** each new use of tripod.

ALWAYS have a minimum of three people present when installing or removing this tripod.

NEVER adjust your stand while in use. Practice the attachment of this tripod at ground level before using in a hunting environment. **ALWAYS** ensure that you and your tripod are safely secured to a healthy tree. Your tripod **MUST** be attached tightly to the tree and secured in place. If the stand is not secure, it may shift while in use, resulting in serious injury or death.

ALWAYS inspect every ladder section connection every time you use the stand before you leave the ground. If ladder sections are separating, with the help of at least two other people, lower the stand to the ground, make adjustments, and reinstall.

ALWAYS check the ground below the tripod to make sure it is firm and level. Sloping ground or uneven terrain (one side of a rock or root) can cause your tripod to tilt or shift.

ALWAYS maintain three points of contact when climbing the tripod. (Two feet and one hand **or** one foot and two hands.)

DO NOT leave your tripod outside since weather or animals may cause damage. It must be stored inside when not in use.

NEVER wear jewelry or loose fitting clothing, which can cause hazardous conditions. Clothing may be caught in your equipment and cause you to fall. You must always wear non-slip or rubber boots. Shoelaces must be tucked into your boots. Rings and necklaces **MUST NOT** be worn.

NEVER use this tripod with a second person. The tripod is designed for use by **ONE** person.

NEVER let children use this tripod without adult supervision. This tripod is not a toy. No one under the age of 18 should attempt to use this product without direct adult supervision.

DO NOT use tripod if any nuts or bolts or parts are loose, bent, or crooked.

ALWAYS know your physical limitations. Don't take chances. If you start thinking about how high you are, don't go any higher. Instead, choose a minimum height that will allow for safe, effective and comfortable hunting.

ALWAYS lean **forward towards the ladder** as you climb **NEVER** lean out from the tripod for any reason.

Be aware that falls can occur at anytime after leaving the ground.

NEVER remove any safety warning stickers from this product.

Safety must be your first priority during the use of this product.

⚠ WARNING

<p>DO NOT use this ladderstand without reading and following all warnings and instructions before each use. Failure to do so may result in serious injury or death.</p> <p>ALWAYS inspect your ladderstand before each use. DO NOT use if parts are missing, worn, or damaged.</p> <p>ALWAYS wear a Full Body Harness while using this ladderstand. Failure to wear a full body harness while using this ladderstand may result in serious injury or death.</p> <p>DO NOT exceed the ladderstand's 300 lbs. weight limit which includes your body weight as well as weight of your clothes and gear. Exceeding the ladderstand's weight limit may cause the treestand to break or fail resulting in serious injury or death.</p>	<p>NEVER stand on treestand seat or any other part of these parts may cause the treestand to break or fail resulting in serious injury or death.</p> <p>NEVER alter, modify, or repair the ladderstand. Failure to do so may result in serious injury or death.</p> <p>NEVER use the ladderstand if you are tired, dizzy, or on medication. NEVER use the ladderstand if you are ill, have a disease, are leaning, or on wet, icy, or slippery ground. NEVER use the ladderstand if the tree may fall, break, or root an anchor may result in serious injury or death.</p> <p>NEVER use the ladderstand during inclement weather. DO NOT use the ladderstand during thunderstorms or any other weather conditions including (but not limited to) lightning, freezing rain, high wind that could create slippery or dangerous conditions.</p>	<p>DO NOT use the ladderstand under the influence of alcohol, drugs, or medication. Using the ladderstand under the influence of alcohol, drugs, or medication may result in serious injury or death.</p> <p>DO NOT use the ladderstand if you have dizzy spells, a heart problem, are afraid of heights, have been advised by a doctor or other health care provider not to climb, or have any condition that would impair your ability to climb up or down or use treestand as it could result in serious injury or death. NEVER remove or deface ladderstand warning labels. Replacement labels can be obtained from the address below.</p>
---	---	---



MODEL: 8015

15' TRIPOD

- Weight Limit 300 lbs.
- Do Not Over Tighten Fasteners

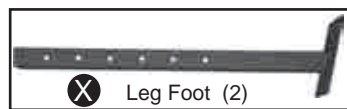
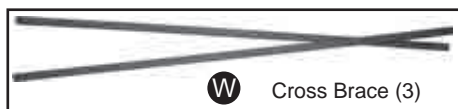
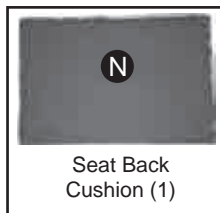
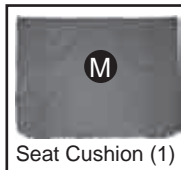
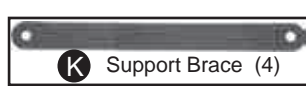
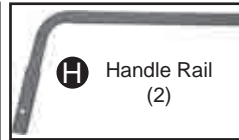
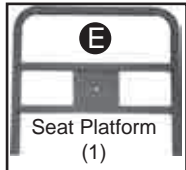
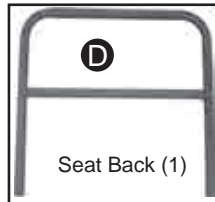
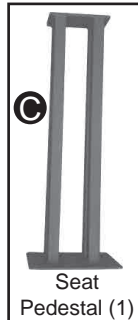
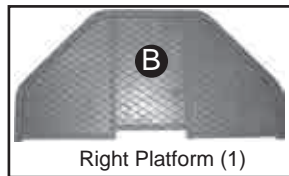
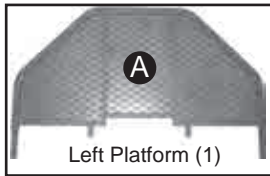

PARTS LIST

- | | | | |
|----------|---|----------------------------|-----------------|
| A | 1 | Left Platform..... | Part # WLP-600 |
| B | 1 | Right Platform..... | Part # WRP-600 |
| C | 1 | Seat Pedestal..... | Part # WSP-600 |
| D | 1 | Seat Back..... | Part # WSB-600 |
| E | 1 | Seat Platform..... | Part # WSP-610 |
| F | 2 | Shooting Rail..... | Part # WSR-600 |
| G | 2 | Armrest..... | Part # WAR-600 |
| H | 2 | Handle Rail..... | Part # WHR-600 |
| J | 2 | Rear Leg Brace..... | Part # WRLB-600 |
| K | 4 | Support Brace..... | Part # WSRB-600 |
| L | 2 | Armrest Cover..... | Part # WARC-600 |
| M | 1 | Seat Cushion..... | Part # WSC-610 |
| N | 1 | Seat Back Cushion..... | Part # WSC-611 |
| O | 4 | Shooting Rail Cover..... | Part # WSRC-600 |
| P | 4 | Shooting Rail Support..... | Part # WSRS-600 |
| R | 2 | Upper Leg..... | Part # WL-600 |
| S | 2 | Lower Leg..... | Part # WL-610 |
| T | 6 | Male Brace..... | Part # WB-600 |
| U | 1 | Top Ladder..... | Part # WTL-600 |
| V | 1 | Bottom Ladder..... | Part # WBL-600 |
| W | 3 | Cross Brace..... | Part # WCB-600 |
| X | 2 | Leg Foot..... | Part # WLF-650 |
| Y | 4 | Anchor Pin..... | Part # WAP-600 |

HARDWARE

- | | | | |
|------------|----|----------------------|--------------|
| 110 | 2 | M12x110mm Bolt | Part # 12110 |
| 75 | 4 | M12x75mm Bolt..... | Part # 1275 |
| 65 | 4 | M12x65mm Bolt..... | Part # 1265 |
| 55 | 24 | M12x55mm Bolt..... | Part # 1255 |
| 45 | 8 | M12x45mm Bolt..... | Part # 1245 |
| 40 | 22 | M12x40mm Bolt..... | Part # 1240 |
| 30 | 8 | M10x30mm Bolt..... | Part # 1030 |

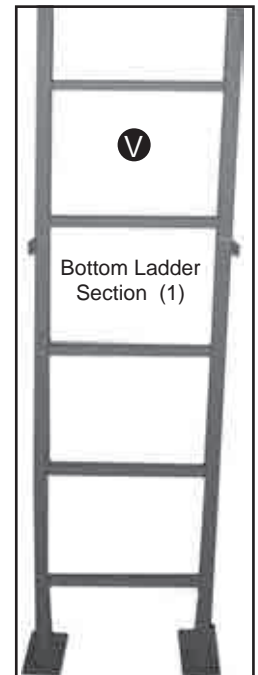
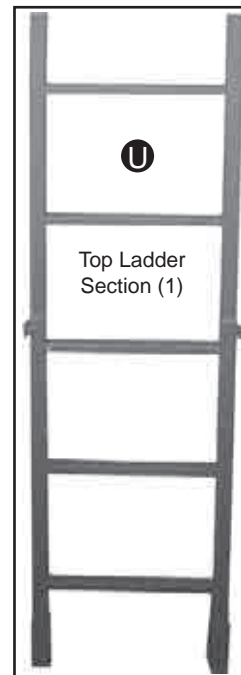

Distributed by Primal Vantage Company Inc. 685 Route 10 East, Randolph, NJ 07869

CUSTOMER SERVICE DEPARTMENT 1-866-972-6168

WWW.PRIMALVANTAGE.COM

©2013 (rev. 03/13)

ALL PHOTOS TAKEN FROM FRONT VIEW UNLESS OTHERWISE NOTED

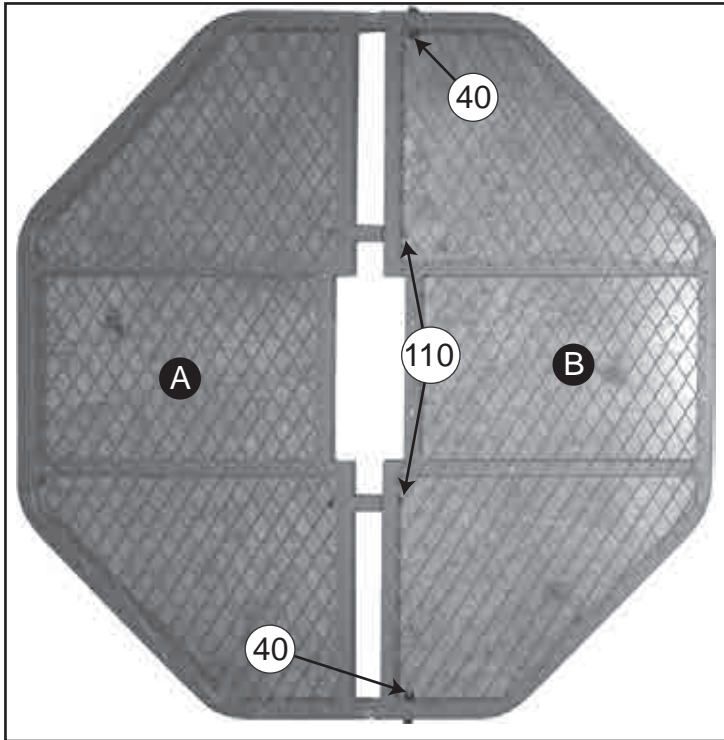

1. Slide Left Platform **A** into Right Platform **B**. Use **1-M12x40mm Bolt** on each side of platform. Use **2-M12x110mm Bolt** in the middle of the platform. Set aside for future use.

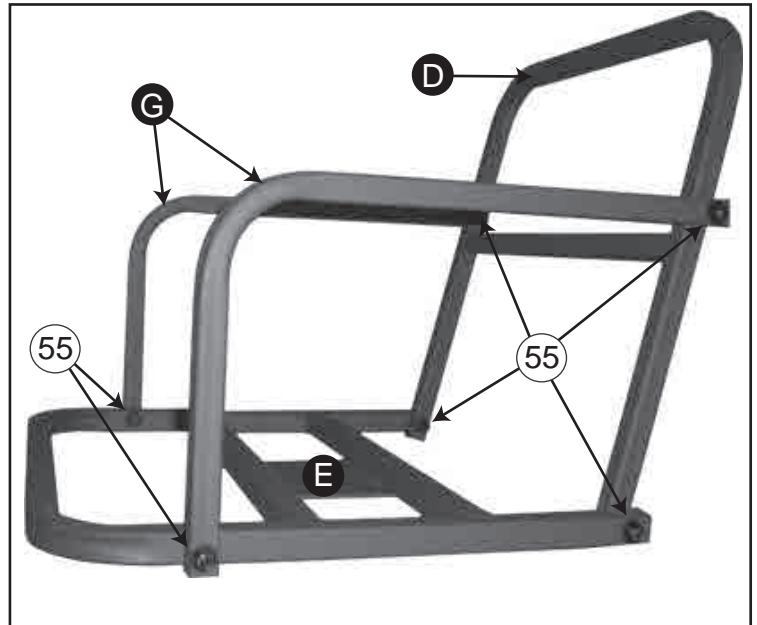

2. Attach Seat Back **D** to Seat Platform **E** using **1-M12x55mm Bolt** on each side.

Attach Armrest **G** to Seat Back **D** and Seat Platform **E** using **2-M12x55mm Bolt** at each connection point. Set aside for future use.

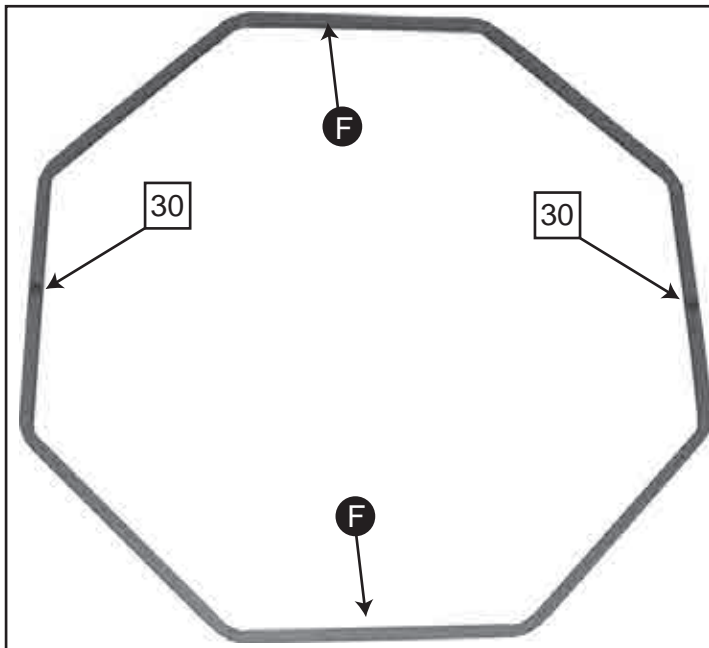

3. Slide both halves of Shooting Rail **F** together and secure with **1-M10x30mm Bolt** on each side. Set aside for future use.

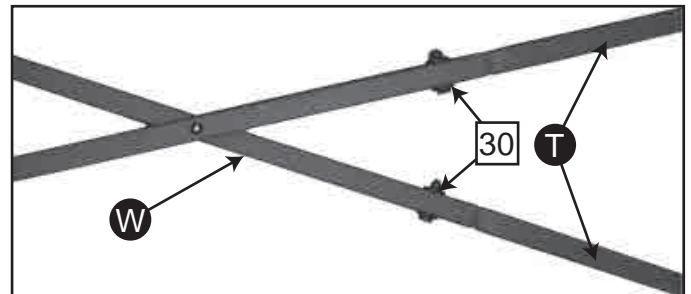

4. Insert the crimped end of Male Brace **T** into the end of Cross Brace **W** near the pivot point. Insert **1-M10x30mm Bolt** at each point. Do this for **ALL** remaining Cross Braces. Set aside for future use.



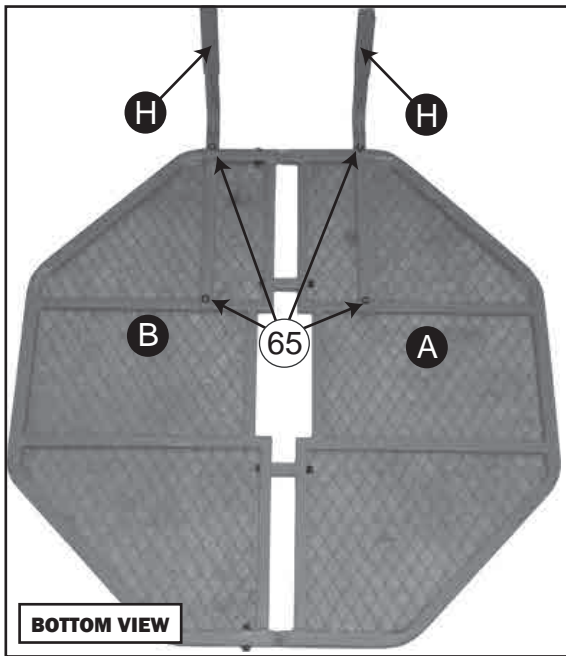

5. Turn the assembled platform over so that the top of the platform is on the ground.

Attach Handle Rail **H** to the bottom of the assembled platform using **2-M12x65mm Bolts** for each Handle Rail.

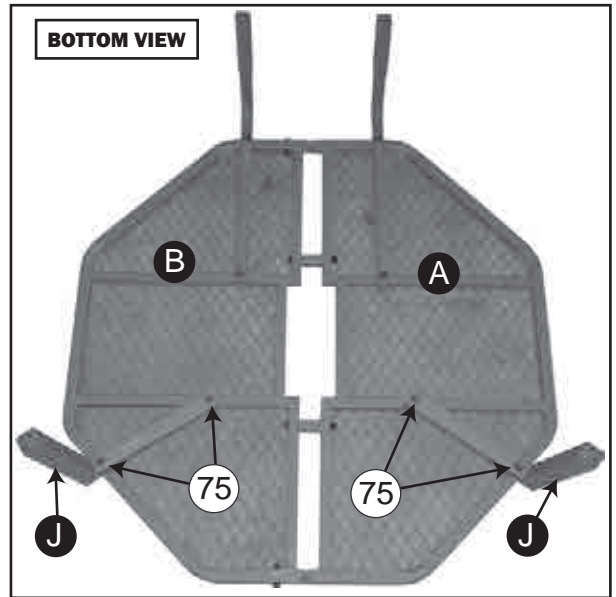

6. With the platform still upside down, Attach Rear Leg Brace **J** to the rear of the platform using **2-M12x75mm Bolts** for each Rear Leg Brace.

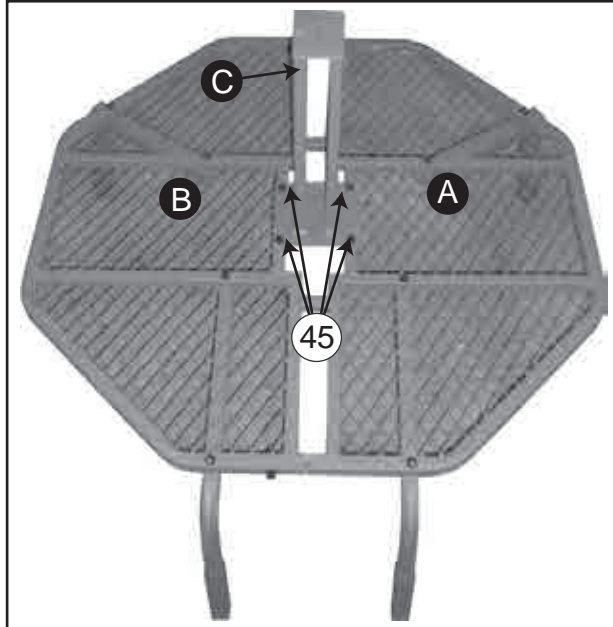

7. Turn the platform upright.

Attach Seat Pedestal **C** to the center of the platform using **4-M12x45mm Bolts**.

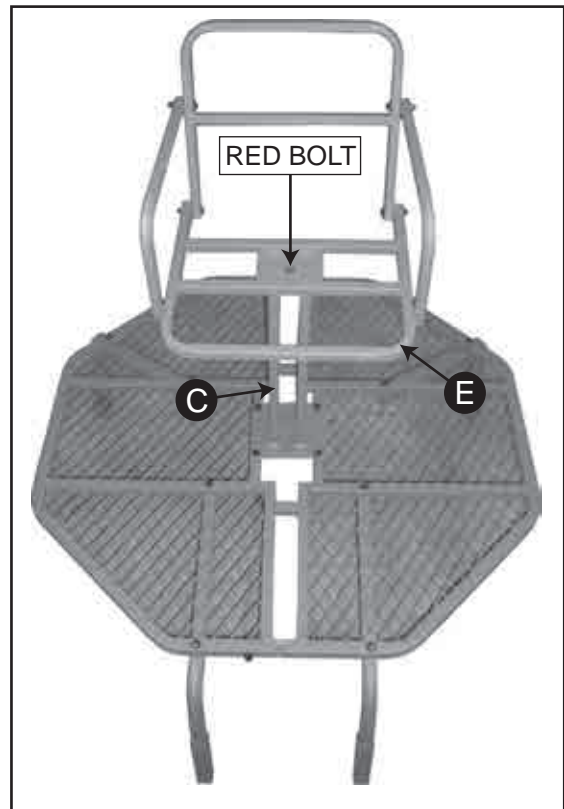

8. Disassemble the **RED Bolt with Large Washer**.

Place the Large Washer on top of the Seat Pedestal **C**. Hold the assembled Seat on the Seat Pedestal. Place a metal washer onto the **RED** bolt, then insert a nylon washer on the bolt. Insert the bolt through the Seat Platform, Large Washer, and the Seat Pedestal. Place another nylon washer onto the bolt, then the last metal washer and tighten the nut.



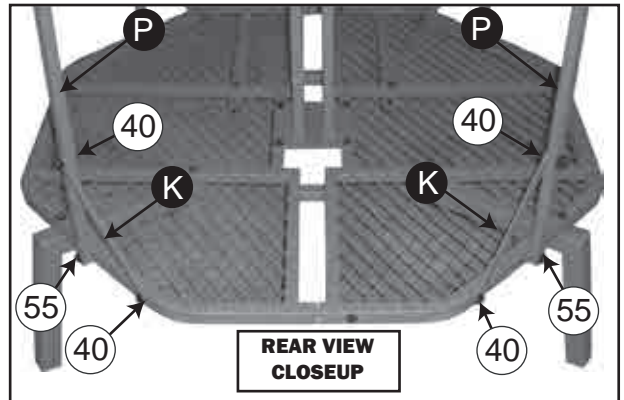
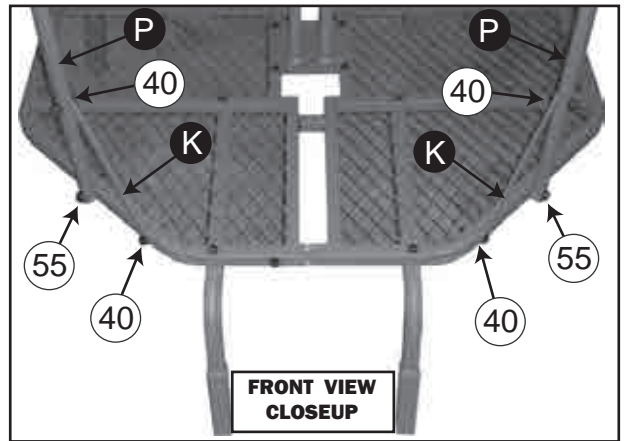
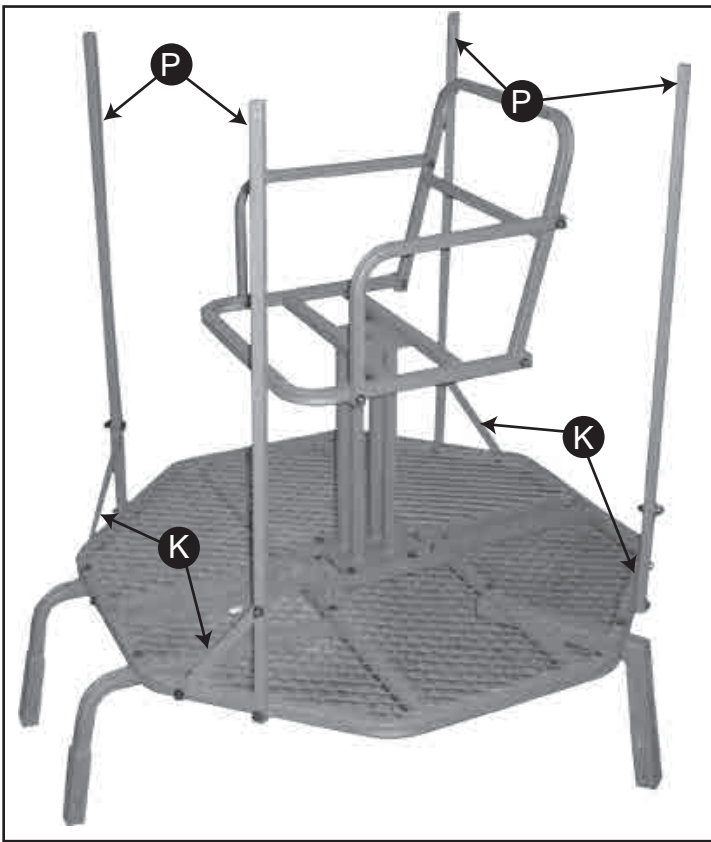

9. Attach Shooting Rail Support **(P)** to the assembled platform using **1-M12x55mm Bolt** for each piece.
(See **Close-Up Photo** for correct placement).

Attach Support Brace **(K)** to the assembled platform and to the **INSIDE** of the Shooting Rail Supports using **1-M12x40mm Bolt** for each connection point. (See **Close-Up Photo** for correct placement).

10. Attach assembled Shooting Rail **(F)** to each Shooting Rail Support **(P)** using **1-M12x55mm Bolt** at each connection point.

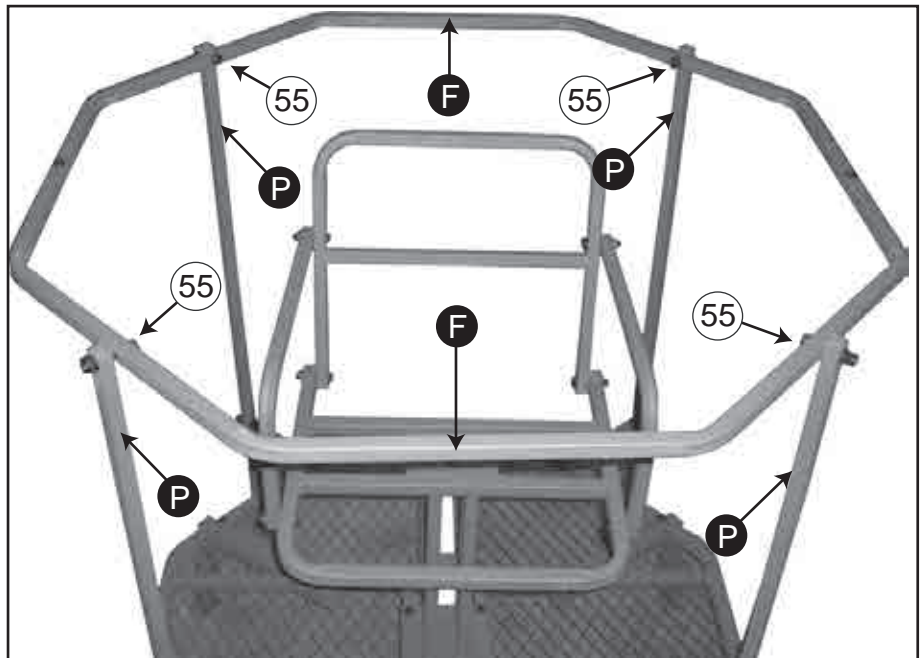

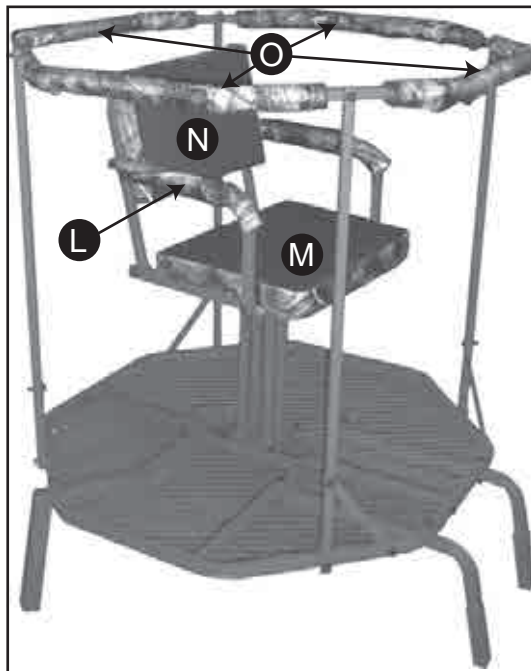

11. Attach each Shooting Rail Cover **O** to Shooting Rail **F** .
 Attach Each Armrest Cover **L** to each Armrest **G** .
 Attach Seat Back Cushion **N** to Seat Back **D** .
 Attach Seat Cushion **M** to Seat Platform **E** .

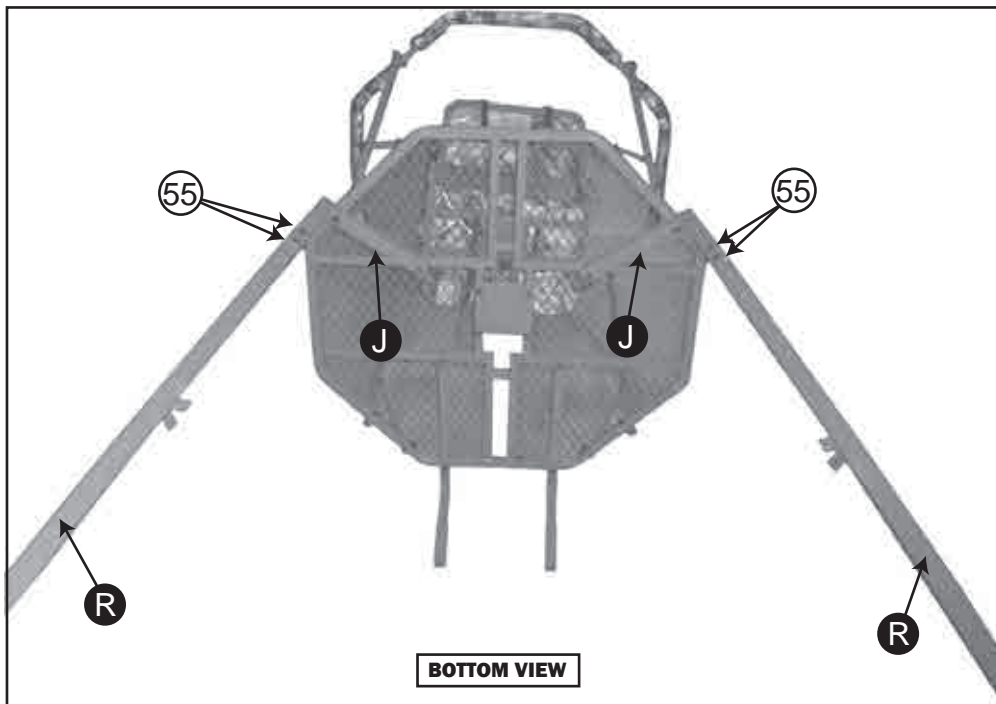

12. Lean the tripod on its front, so that the handle rails are on the ground and the rear leg braces are facing up.

Insert Upper Leg **R** into Rear Leg Brace **J** . (The Upper Leg has 2 holes on the Bottom). The brackets on the legs **MUST** be facing towards the inside of the stand. Secure with **2-M12x55mm Bolts** on each leg.



Distributed by Primal Vantage Company Inc. 685 Route 10 East, Randolph, NJ 07869

©2013 (rev. 03/13)

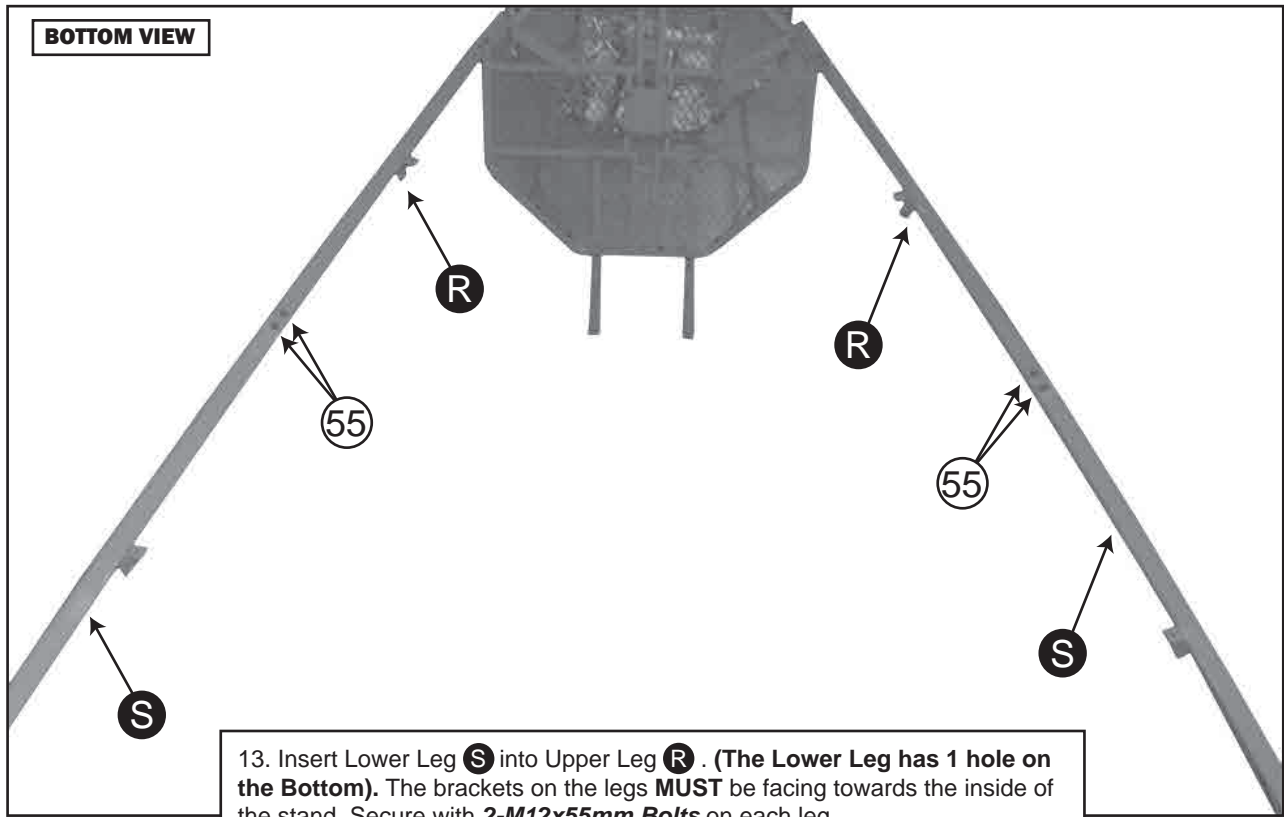

13. Insert Lower Leg **S** into Upper Leg **R**. (The Lower Leg has 1 hole on the Bottom). The brackets on the legs **MUST** be facing towards the inside of the stand. Secure with **2-M12x55mm Bolts** on each leg.

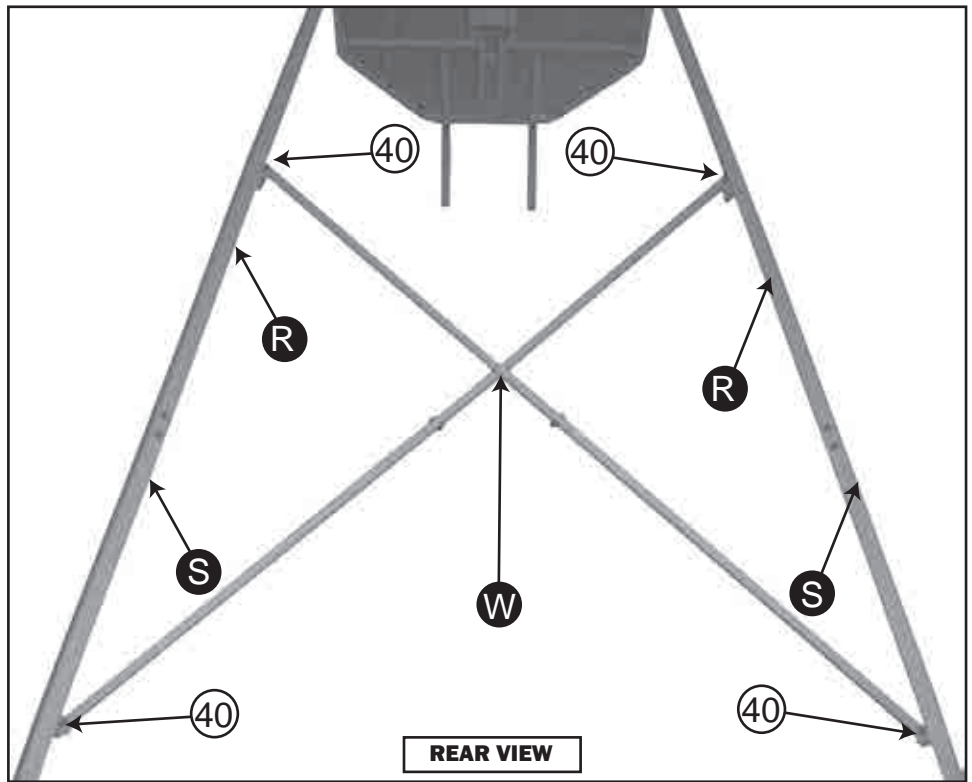
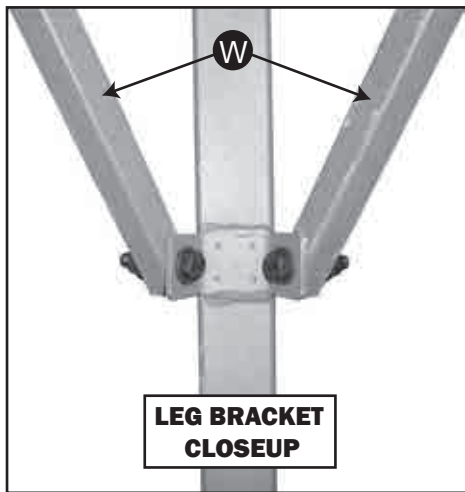

14. Attach one Cross Brace **W** to the Upper Leg **R** and Lower Legs **S** using **1-M12x40mm Bolt** at each point. Attach Braces to the **OUTSIDE** of the Brackets



Distributed by Primal Vantage Company Inc. 685 Route 10 East, Randolph, NJ 07869

©2013 (rev. 03/13)

WITH THE HELP AT AT LEAST TWO OTHER PEOPLE, TURN THE TRIPOD SO THAT THE HANDLE RAILS ARE FACING UP AND THE REAR LEG BRACES ARE ON THE GROUND.

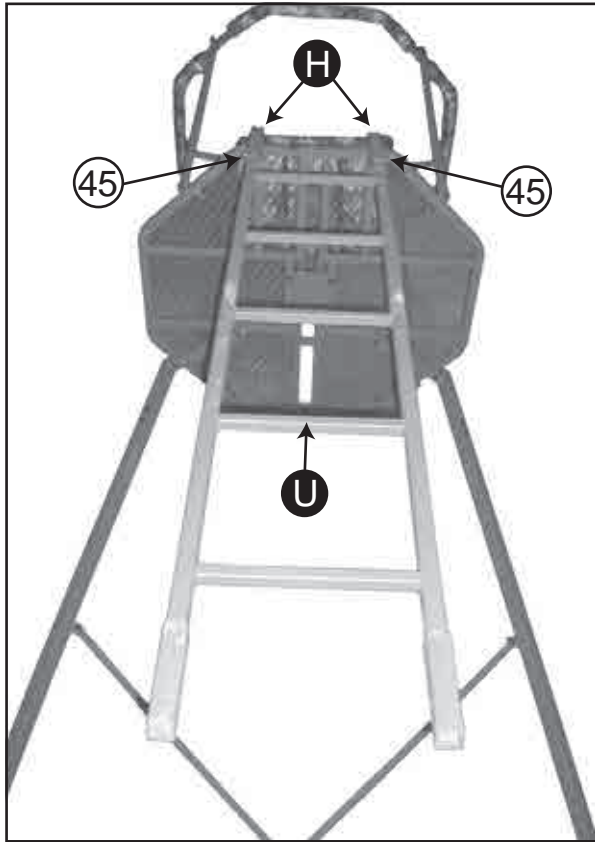

15. Insert Top Ladder Section **U** into Handle Rails **H**. The brackets on the Ladder Section **MUST** be facing towards the inside of the stand. Secure using **1-M12x45mm Bolt** on each side.

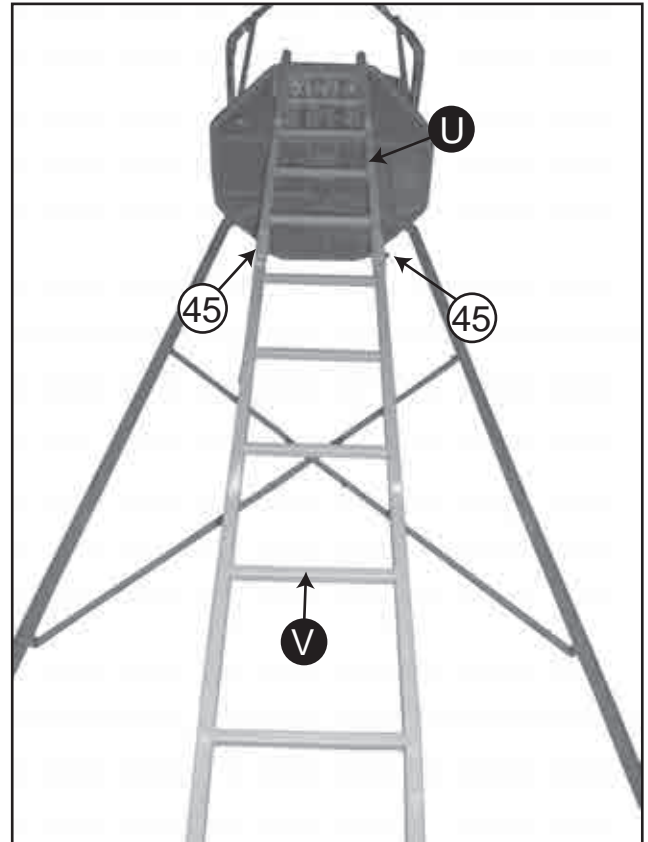

16. Insert Bottom Ladder Section **V** into Top Ladder Section **U**. The brackets on the Ladder Section **MUST** be facing towards the inside of the stand. Secure using **1-M12x45mm Bolt** on each side.

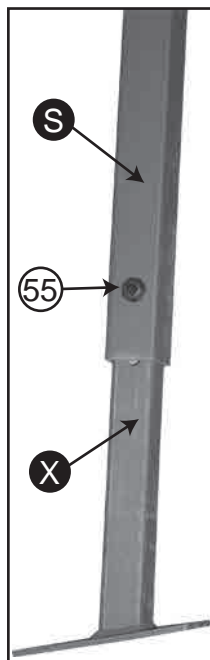

17. Insert Foot **X** into Lower Leg **S**.

The Foot is adjustable so you can raise or lower the stand as needed.

Insert **1-M12x55mm Bolt** to secure.



Distributed by Primal Vantage Company Inc. 685 Route 10 East, Randolph, NJ 07869

©2013 (rev. 03/13)

WITH THE HELP AT AT LEAST TWO OTHER PEOPLE , STAND THE TRIPOD UPRIGHT

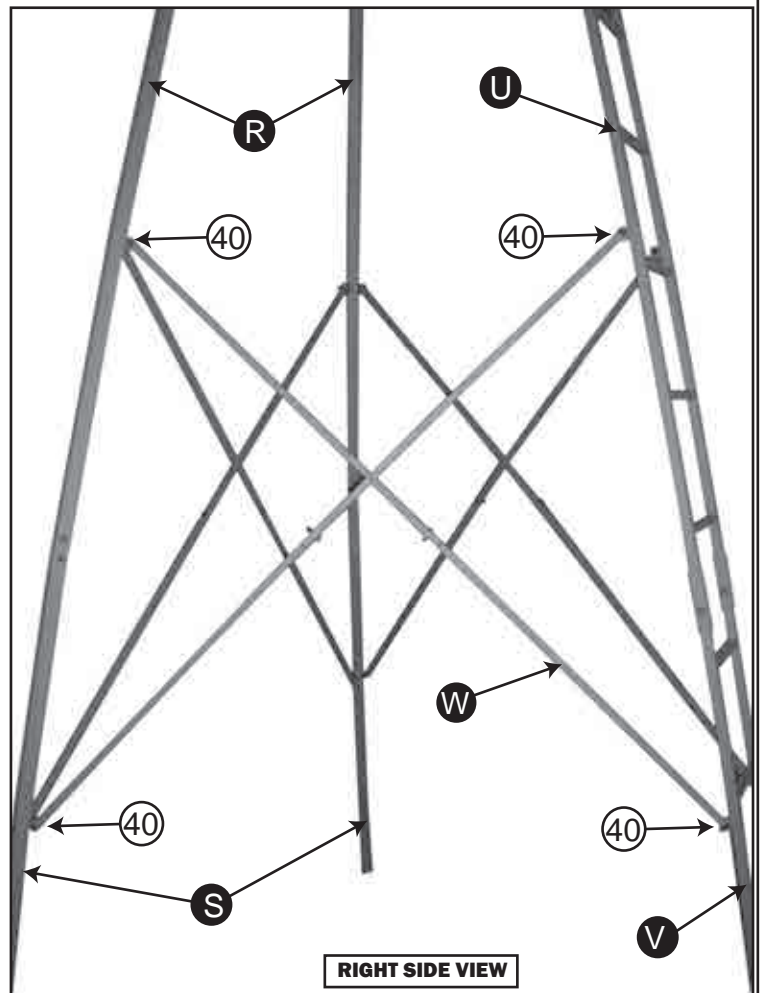
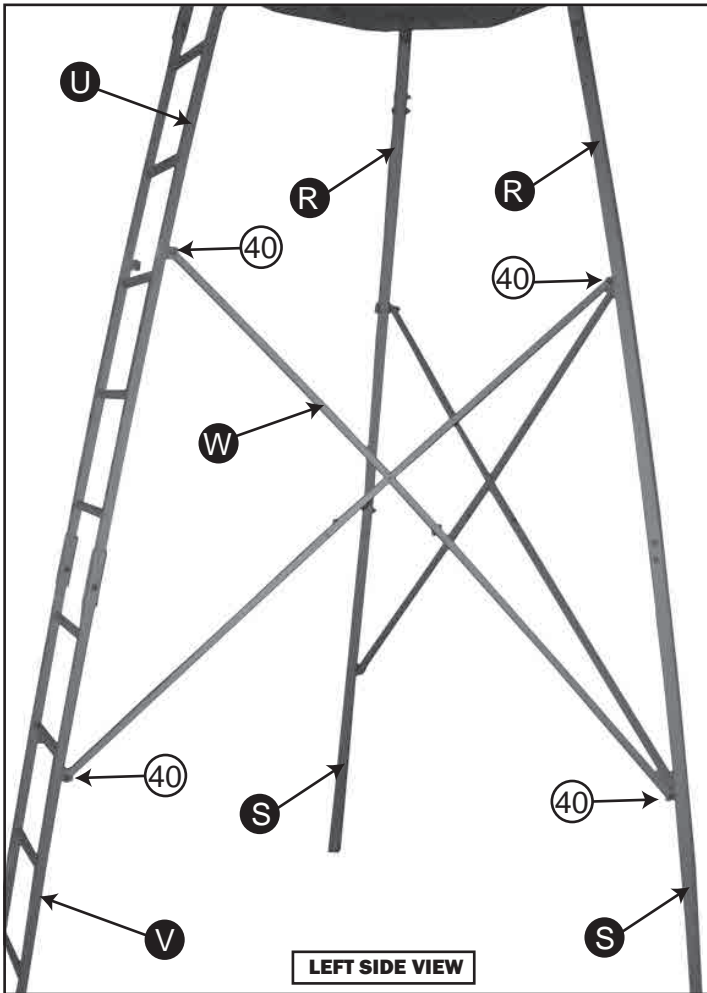

17. Attach another Cross Brace (W) to Top Ladder Section (U) and Lower Leg (S) . Attach the same Cross Brace to Bottom Ladder Section (V) and Upper Leg (R) using 1-M12x40mm Bolt at each point. **Attach Braces to the OUTSIDE of the Brackets.**

18. Attach the last Cross Brace (W) to Top Ladder Section (U) and Lower Leg (S) . Attach the same Cross Brace to Bottom Ladder Section (V) and Upper Leg (R) using 1-M12x40mm Bolt at each point. **Attach Braces to the OUTSIDE of the Brackets.**

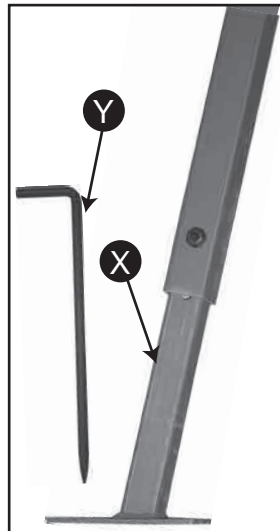
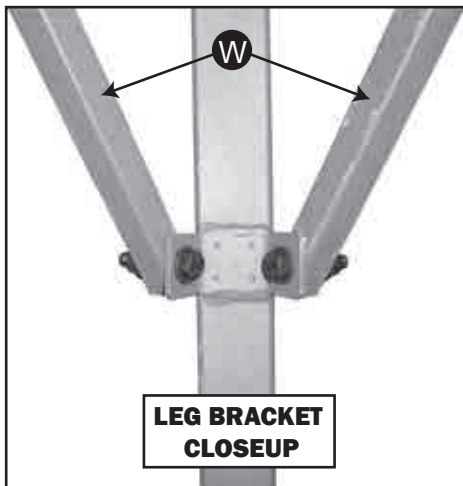

19. Insert Anchor Pin (Y) through the hole on each Foot (X) when the stand is in desired position.

